

B3 B5 B35

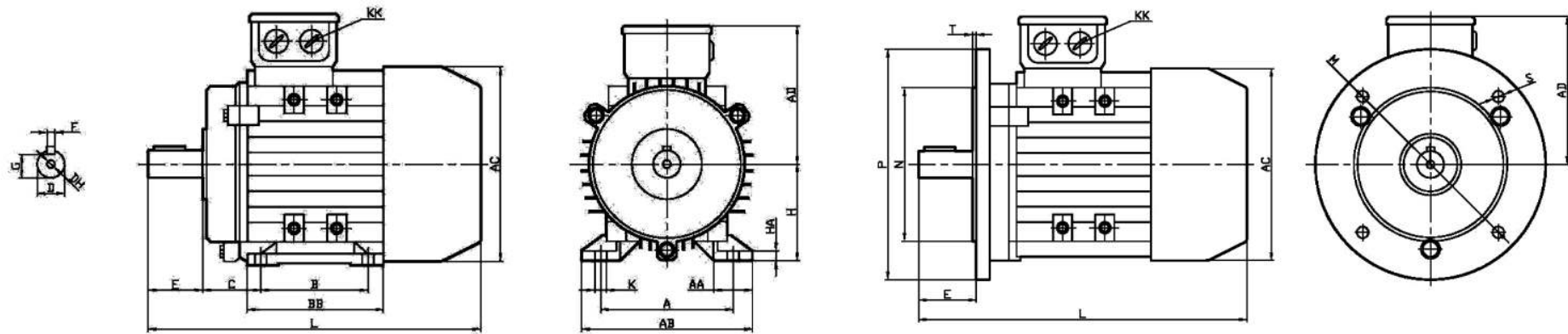

Baugröße	A	AA	AB	AC	AD	B	BB	C	D	DH	E	F	G	H	HA	K	KK	L	M	N	P	S	T
<b>56</b>	90	23	115	110	100	71	88	36	9	M4x12	20	3	7,2	56	7,5	6	M20x1,5	199	100	80	120	7	3
<b>63</b>	100	32	135	130	111	80	105	40	11	M4x12	23	4	8,5	63	9	7	M20x1,5	217	115	95	140	9,5	3
<b>71</b>	112	33	150	145	118	90	112	45	14	M5x12	30	5	11	71	9	7	M20x1,5	245	130	110	160	9,5	3,5
<b>80</b>	125	35	165	175	134	100	125	50	19	M6x12	40	6	15,5	80	9	10	M25x1,5	287	165	130	200	11,5	3,5
<b>90S</b>	140	37	180	195	140	100	125	56	24	M8x19	50	8	20	90	10	10	M25x1,5	315	165	130	200	12	3,5
<b>90L</b>	140	37	180	195	140	125	150	56	24	M8x19	50	8	20	90	10	10	M25x1,5	340	165	130	200	12	3,5
<b>100L</b>	160	40	205	215	160	140	171	63	28	M10x22	60	8	24	100	11	12	M32x1,5	385	215	180	250	15	4
<b>112M</b>	190	42	230	240	178	140	181	70	28	M10x22	60	8	24	112	13	12	M32x1,5	400	215	180	250	15	4
<b>132S</b>	216	50	270	275	206	140	186	89	38	M12x28	80	10	33	132	15	12	M32x1,5	483	265	230	300	14	4
<b>132M</b>	216	50	270	275	206	178	223	89	38	M12x28	80	10	33	132	15	12	M32x1,5	510	265	230	300	14	4
<b>160M</b>	254	60	320	330	255	210	260	108	42	M16x36	110	12	37	160	18	15	M40x1,5	615	300	250	350	18	5
<b>160L</b>	254	60	320	330	255	254	304	108	42	M16x36	110	12	37	160	18	15	M40x1,5	670	300	250	350	18	5

**B14 F1**

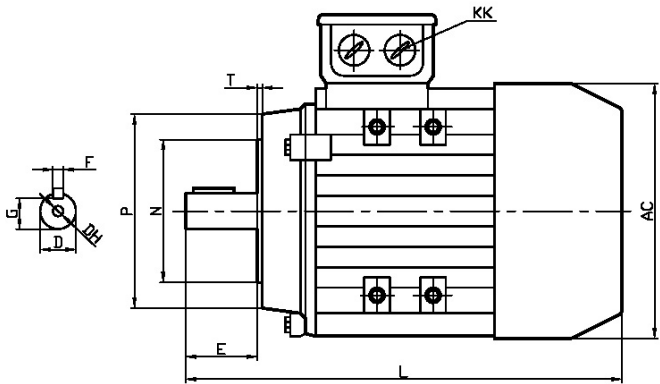

**B14 F2**

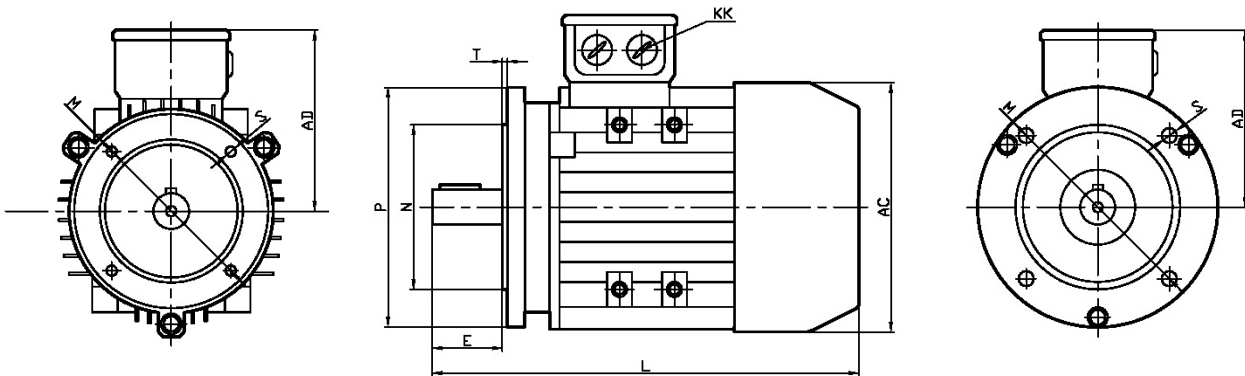

Baugröße	B14 klein (F1)										B14 groß (F2)								
	AC	AD	D	DH	E	F	G	KK	L	M	N	P	S	T	M	N	P	S	T
<b>56</b>	110	100	9	M4x12	20	3	7,2	M20x1,5	170	65	50	80	M5	2,5	85	70	105	M6	2,5
<b>63</b>	130	111	11	M4x12	23	4	8,5	M20x1,5	225	75	60	90	M5	2,5	100	80	120	M6	2,5
<b>71</b>	145	118	14	M5x12	30	5	11	M20x1,5	250	85	70	105	M6	2,5	115	95	140	M8	3
<b>80</b>	175	134	19	M6x12	40	6	15,5	M25x1,5	295	100	80	120	M6	3	130	110	160	M8	3,5
<b>90S</b>	195	140	24	M8x19	50	8	20	M25x1,5	315	115	95	140	M8	3	130	110	160	M8	3,5
<b>90L</b>	195	140	24	M8x19	50	8	20	M25x1,5	340	115	95	140	M8	3	130	110	160	M8	3,5
<b>100L</b>	215	160	28	M10x22	60	8	24	M32x1,5	385	130	110	160	M8	3,5	165	130	200	M10	3,5
<b>112M</b>	240	178	28	M10x22	60	8	24	M32x1,5	400	130	110	160	M8	3,5	165	130	200	M10	3,5
<b>132S</b>	275	206	38	M12x28	80	10	33	M32x1,5	470	165	130	200	M10	3,5	215	180	250	M12	4
<b>132M</b>	275	206	38	M12x28	80	10	33	M32x1,5	510	165	130	200	M10	3,5	215	180	250	M12	4
<b>160M</b>	330	255	42	M16x36	110	12	37	M40x1,5	615	215	180	250	M12	4	265	230	300	M12	4
<b>160L</b>	330	255	42	M16x36	110	12	37	M40x1,5	670	215	180	250	M12	4	265	230	300	M12	4

**B34**

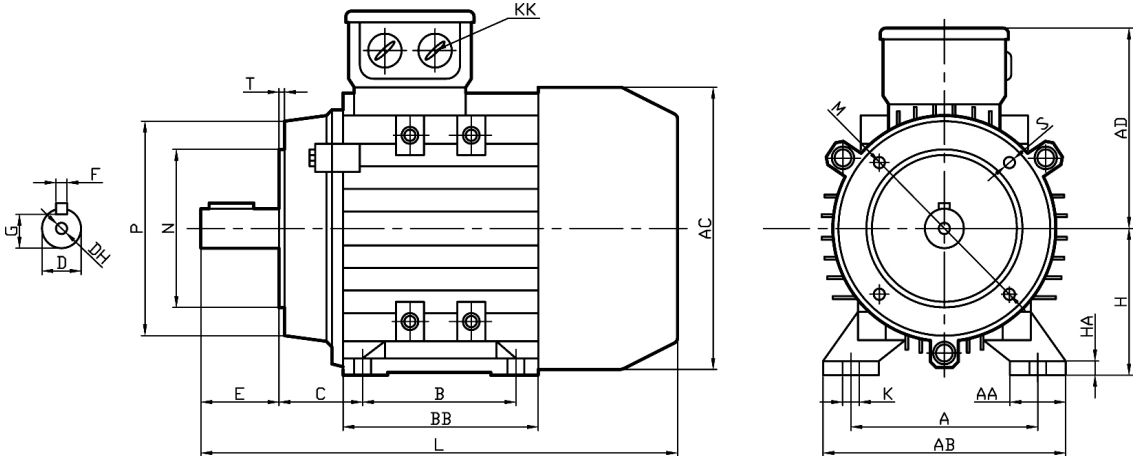

Baugröße	A	AA	AB	AC	AD	B	BB	C	D	DH	E	F	G	H	HA	K	KK	L	M*	N*	P*	S*	T*
<b>56</b>	90	23	115	110	100	71	88	36	9	M4x12	20	3	7,2	56	7,5	6	M20x1,5	199	65	50	80	M5	2,5
<b>63</b>	100	32	135	130	111	80	105	40	11	M4x12	23	4	8,5	63	9	7	M20x1,5	217	75	60	90	M5	2,5
<b>71</b>	112	33	150	145	118	90	112	45	14	M5x12	30	5	11	71	9	7	M20x1,5	245	85	70	105	M6	2,5
<b>80</b>	125	35	165	175	134	100	125	50	19	M6x12	40	6	15,5	80	9	10	M25x1,5	287	100	80	120	M6	3
<b>90S</b>	140	37	180	195	140	100	125	56	24	M8x19	50	8	20	90	10	10	M25x1,5	315	115	95	140	M8	3
<b>90L</b>	140	37	180	195	140	125	150	56	24	M8x19	50	8	20	90	10	10	M25x1,5	340	115	95	140	M8	3
<b>100L</b>	160	40	205	215	160	140	171	63	28	M10x22	60	8	24	100	11	12	M32x1,5	385	130	110	160	M8	3,5
<b>112M</b>	190	42	230	240	178	140	181	70	28	M10x22	60	8	24	112	13	12	M32x1,5	400	130	110	160	M8	3,5
<b>132S</b>	216	50	270	275	206	140	186	89	38	M12x28	80	10	33	132	15	12	M32x1,5	483	165	130	200	M10	3,5
<b>132M</b>	216	50	270	275	206	178	223	89	38	M12x28	80	10	33	132	15	12	M32x1,5	510	165	130	200	M10	3,5
<b>160M</b>	254	60	320	330	255	210	260	108	42	M16x36	110	12	37	160	18	15	M40x1,5	615	215	180	250	M12	4
<b>160L</b>	254	60	320	330	255	254	304	108	42	M16x36	110	12	37	160	18	15	M40x1,5	670	215	180	250	M12	4

\* Maße für B34 F1, für B34 F2 siehe B14 F2