

ACCESSORIES
SUPPLIED AND PACKED
WITH THE MOTOR
(Accessori Forniti ed Imballati
con il Motore)

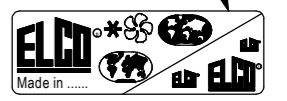
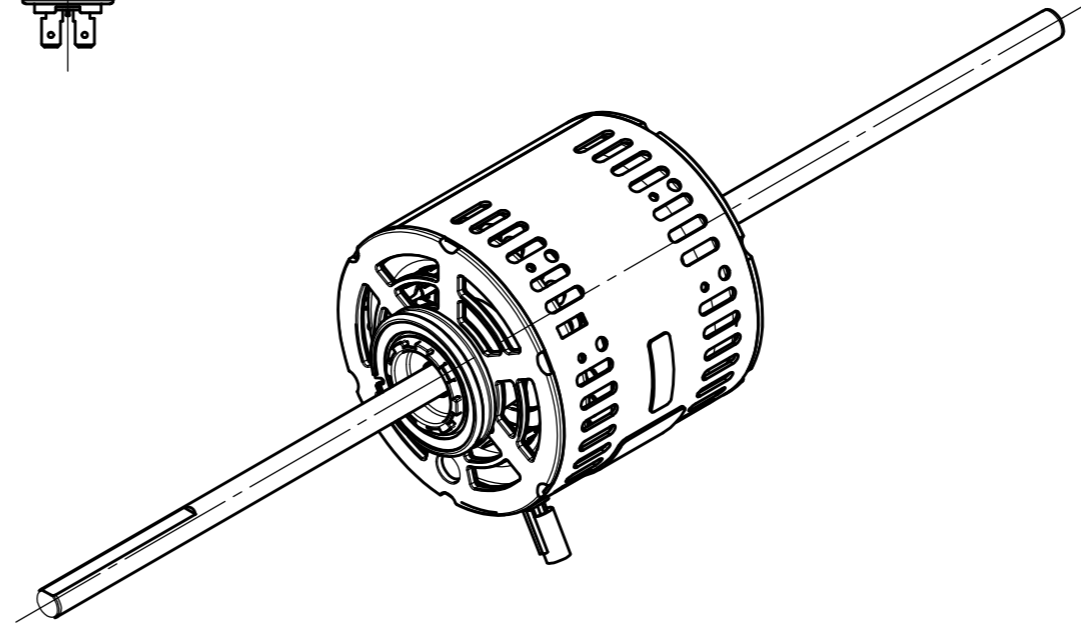
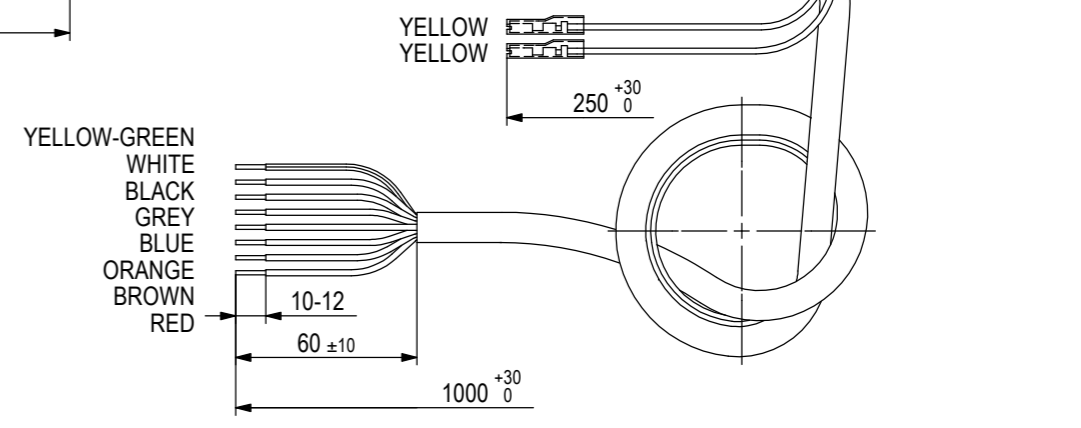

CODE: FGFB46TB0543
TYPE: 1FG 180-50-6V NA

230V ~ 50Hz 1,40A
180/310W 1300Rpm TH.PROT
INS.CL.B C=5µF 450VL

WHITE	COMMON
BLACK	MAX-1 VEL.
GREY	2 VEL.
BLUE	3 VEL.
ORANGE	4 VEL.
BROWN	5 VEL.
RED	MIN-6 VEL.
YELLOW	
YELLOW/GREEN	

DATA

CLASS "B" MOTOR - SLEEVE BEARINGS MANUFACTURED (Motore in classe "B" - Esecuzione a Bronzine)	
AXIAL CLEARANCE (Gioco assiale)	1,0 - 3,5 mm
SHELL (Fascia)	OPEN (Aperta)
END SHIELD - LEADS SIDE (Coperchio lato Cavi)	OPEN (Aperto)
END SHIELD - OPPOSITE LEADS SIDE (Cop. lato opposto cavi)	OPEN (Aperto)
ASSEMBLING SPECIFICATION No. (Normativa per note di montaggio)	EL.UN.0009
MECHANICAL SPECIFICATION No. (Normativa per note di controllo meccanico)	EL.CM.0002
ELECTRICAL SPECIFICATION No. (Controllo elettrico con prescrizione)	M.1678/ 1

Rel.	Date	Description	Executor signature	Checked

	For dimension without tolerance see standard UNI EN 22768-mK	Treatment	A3
	Material		
Drawn Pedrini R. Date 21-06-2018 Check <i>E. Crigora</i> Scale ---	SINGLE PHASE MOTOR MOTOR 1 FG 180-50-6V NA 230V 50Hz Th.Prot. CL.B		Weight gr. Ref. No 4-010-821 Release -
FGFB46TB0543			